

Power Over Ethernet (PoE/PoE+) Operation

Contents

Introduction to PoE	11-2
PoE Terminology	11-2
PoE Operation	11-4
Configuration Options	11-4
PD Support	11-5
Power Priority Operation	11-6
When Is Power Allocation Prioritized?	11-6
How Is Power Allocation Prioritized?	11-6
Configuring PoE Operation	11-7
Disabling or Re-Enabling PoE Port Operation	11-7
Enabling Support for Pre-Standard Devices	11-7
Configuring the PoE Port Priority Level	11-8
PoE Priority With Two or More Modules	11-9
Controlling PoE Allocation	11-11
Manually Configuring PoE Power Levels	11-12
Configuring PoE Redundancy (Chassis Switches Only)	11-13
Changing the Threshold for Generating a Power Notice	11-14
PoE/PoE+ Allocation Using LLDP Information	11-17
LLDP with PoE	11-17
Displaying the Switch's Global PoE Power Status	11-18
Displaying PoE Status on All Ports	11-20
Displaying the PoE Status on Specific Ports	11-22
Planning and Implementing a PoE Configuration	11-24
Power Requirements	11-24
Assigning PoE Ports to VLANs	11-25
Applying Security Features to PoE Configurations	11-25
Assigning Priority Policies to PoE Traffic	11-25

PoE Event Log Messages	11-27
“Informational” PoE Event-Log Messages	11-27
“Warning” PoE Event-Log Messages	11-28

Introduction to PoE

PoE technology allows IP telephones, wireless LAN access points, and other appliances to receive power and transfer data over existing ethernet LAN cabling. For more information about PoE technology, refer to the *PoE Planning and Implementation Guide*, which is available on the ProCurve Networking web site at www.procurve.com. Select **Support** and then click on **Manuals**.

PoE Terminology

PoE and PoE+ operate similarly in most cases. The CLI commands are the same for a PoE module or a PoE+ zl module. Any differences between PoE and PoE+ operation will be noted, otherwise the term “PoE” is used to designate both PoE and PoE+ functionality.

Term	Use in this Manual
active PoE port	A PoE-enabled port connected to a PD requesting power.
DTE	Data Terminal Equipment
MPS	Maintenance Power Signature; the signal a PD sends to the switch to indicate that the PD is connected and requires power.
Oversubscribed	The state where there are more PDs requesting PoE power than can be accommodated.
PD	Powered Device. This is an IEEE 802.3af-compliant or IEEE 802.3at-compliant device that receives its power through a direct connection to a PoE port in a PoE device. Examples of PDs include Voice-over-IP (VoIP) telephones, wireless access points, and remote video cameras.
PoE	Power-Over-Ethernet; the method by which PDs receive power from a PoE module (operates according to the IEEE 802.3af standard). Some pre-standard PoE devices are also supported; refer to the FAQs for your switch model.
PoE+ (POEP)	Power-over-Ethernet Plus; the method by which PDs receive power according to the 802.3at standard. It is backward compatible with devices using the 802.3af standard.
PoE Module	Refers to a PoE Module for the switches covered in this guide.

Term	Use in this Manual
port-number priority	Refers to the type of power prioritization where, within a priority class, a PoE module assigns the highest priority to the lowest-numbered port in the module, the second-highest priority to the second lowest-numbered port in the module, and so on. Note that power priority rules apply only if PoE provisioning on the module becomes oversubscribed.
priority class	Refers to the type of power prioritization that uses Low (the default), High , and Critical priority assignments to determine which groups of ports will receive power. Note that power priority rules apply only if PoE provisioning becomes oversubscribed.
PSE	Power-Sourcing Equipment. A PSE provides power to IEEE 802.3af-compliant or IEEE 802.3at-compliant PDs directly connected to the ports on the module. The PoE module is an <i>endpoint</i> PSE.

PoE Operation

Using the commands described in this chapter, you can:

- Enable or disable PoE operation on individual ports.
- Monitor PoE status and performance per module.
- Configure a non-default power threshold for SNMP and Event Log reporting of PoE consumption on either all PoE ports on the switch or on all PoE ports in one or more PoE modules.
- Specify the port priority you want to use for provisioning PoE power in the event that the PoE resources become oversubscribed.

A PSE detects the power needed by a PD before supplying that power, a detection phase referred to as “searching”. If the PSE can’t supply the required amount of power, it does not supply any power. For PoE using a Type 1 device, a PSE will not supply any power to a PD unless the PSE has at least 17 W available. For example, if a PSE has a maximum available power of 382W and is already supplying 378W, and is then connected to a PD requiring 10W, the PSE will not supply power to the PD.

For PoE+ using Type 2 devices, the PSE must have at least 33 W available. A slot in a zl chassis can provide a maximum of 370 watts of PoE/PoE+ power to a module.

Configuration Options

In the default configuration, all ports on the PoE module in a ProCurve switch covered in this guide are configured to support PoE operation. You can:

- Disable or re-enable per-port PoE operation on individual ports to help control power usage and avoid oversubscribing PoE resources.
- Configure per-port priority for allocating power in case a PoE module becomes oversubscribed and must drop power for some lower-priority ports to support the demand on other, higher-priority ports.
- Manually allocate the amount of PoE power for a port by usage, value, or class.
- Allocate PoE power based on the link-partner’s capabilities via LLDP.

Note

The ports support standard networking links and PoE links. You can connect either a non-PoE device or a PD to a port enabled for PoE without reconfiguring the port.

PD Support

To best utilize the allocated PoE power, spread your connected PoE devices as evenly as possible across modules. Depending on the amount of power the power supply device delivers to a PoE module, there may or may not always be enough power available to connect and support PoE operation on all the ports in the module. When a new PD connects to a PoE module and the module does not have enough power left for that port:

- If the new PD connects to a port “X” having a *higher* PoE priority than another port “Y” that is already supporting another PD, then the power is removed from port “Y” and delivered to port “X”. In this case the PD on port “Y” loses power and the PD on port “X” receives power.
- If the new PD connects to a port “X” having a *lower* priority than all other PoE ports currently providing power to PDs, then power is not supplied to port “X” until one or more PDs using higher priority ports are removed.

In the default configuration (**usage**), when a PD connects to a PoE port and begins operating, the port retains only enough PoE power to support the PD’s operation. Unused power becomes available for supporting other PD connections. However, if you configure the **poe-allocate-by** option to either **value** or **class**, then all of the power configured is allocated to the port.

For PoE (not PoE+), while 17 watts must be available for a PoE module on the switch to begin supplying power to a port with a PD connected, 17 watts per port is not continually required if the connected PD requires less power. For example, with 20 watts of PoE power remaining available on a module, you can connect one new PD without losing power to any currently connected PDs on that module. If that PD draws only 3 watts, then 17 watts remain available and you can connect at least one more PD to that module without interrupting power to any other PoE devices connected to the same module. If the next PD you connect draws 5 watts, then only 12 watts remain unused. With only 12 unused watts available, if you then connect yet another PD to a higher-priority PoE port, then the lowest-priority port on the module loses PoE power and remains unpowered until the module once again has 17 or more watts available. (For information on power priority, refer to “Power Priority Operation” on page 11-7.)

For PoE+, there must be 33 watts available for the module to begin supplying power to a port with a PD connected. A slot in a zl chassis can provide a maximum of 370 watts of PoE/PoE+ power to a module.

Disconnecting a PD from a PoE port causes the module to stop providing PoE power to that port and makes the power available to any other PoE ports that have PDs connected and waiting for power. If the PD demand for power becomes greater than the PoE power available, then power is transferred from the lower-priority ports to the higher-priority ports. (Ports not currently providing power to PDs are not affected.)

Power Priority Operation

When Is Power Allocation Prioritized?

If a PSE can provide power for all connected PD demand, it does not use its power priority settings to allocate power. However, if the PD power demand oversubscribes the available power, then the power allocation is prioritized to the ports that present a PD power demand. This causes the loss of power from one or more lower-priority ports to meet the power demand on other, higher-priority ports. This operation occurs regardless of the order in which PDs connect to the module's PoE-enabled ports.

How Is Power Allocation Prioritized?

There are two ways that PoE power is prioritized:

- Using a *priority class* method, a power priority of **Low** (the default), **High**, or **Critical** is assigned to each enabled PoE port.
- Using a *port-number priority* method, a lower-numbered port has priority over a higher-numbered port within the same configured priority class, for example, port A1 has priority over port A5 if both are configured with **High** priority.

Configuring PoE Operation

In the default configuration, PoE support is enabled on the ports in a PoE module installed on the switch. The default priority for all ports is **Low** and the default power notification threshold is **80** (%).

Using the CLI, you can:

- Disable or re-enable PoE operation on individual PoE ports
- Enable support for pre-standard devices
- Change the PoE priority level on individual PoE ports
- Change the threshold for generating a power level notice
- Manually allocate the amount of PoE power for a port by usage, value, or class.
- Allocate PoE power based on the link-partner's capabilities via LLDP.

Disabling or Re-Enabling PoE Port Operation

Syntax: [no] interface <port-list> power-over-ethernet

*Re-enables PoE operation on <port-list> and restores the priority setting in effect when PoE was disabled on <port-list>. The **no** form of the command disables PoE operation on <port-list>. (Default: All PoE ports are initially enabled for PoE operation at **Low** priority. If you configure a higher priority, this priority is retained until you change it.)*

Note: For PoE, disabling all ports allows the 22 W of minimum PoE power or 38 W for PoE+ power allocated for the module to be recovered and used elsewhere. You must disable ALL ports for this to occur.

Enabling Support for Pre-Standard Devices

The ProCurve switches covered in this guide also support some pre-802.3af devices. For a list of the devices supported, refer to the FAQs for your switch model.

Syntax: [no] power-over-ethernet pre-std-detect

Detects and powers pre-802.3af standard devices.

Note: This is enabled by default.

Configuring the PoE Port Priority Level

Syntax: interface < port-list > power-over-ethernet [critical | high | low]

Reconfigures the PoE priority level on <port-list>. For a given level, ports are prioritized by port number in ascending order. For example, if ports A1-A24 have a priority level of critical, port A1 has priority over ports A2-A24.

If there is not enough power available to provision all active PoE ports at a given priority level, then the lowest-numbered port at that level will be provisioned first. For chassis switches, the lowest-numbered port at that level starting with module A, then B, C, and so on is provisioned. PoE priorities are invoked only when all active PoE ports cannot be provisioned (supplied with PoE power).

- **Critical:** Specifies the highest-priority PoE support for <port-list>. The active PoE ports at this level are provisioned before the PoE ports at any other level are provisioned.
- **High:** Specifies the second priority PoE support for <port-list>. The active PoE ports at this level are provisioned before the Low priority PoE ports are provisioned.
- **Low:** (the default): Specifies the third priority PoE support for <port-list>. The active PoE ports at this level are provisioned only if there is power available after provisioning any active PoE ports at the higher priority levels.

*In chassis switches, you can use one command to set the same priority level on PoE ports in multiple modules. For example, to configure the priority to **High** for ports c5-c10, C23-C24, D1-D10, and D12, you could use this command:*

```
ProCurve(config)# interface c5-c10,c23-c24,  
d1-d10,d12 power-over-ethernet high
```

Suppose, for example, that you configure the PoE priority for a module in slot C as shown in table 11-1.

Table 11-1. Example of PoE Priority Operation on a PoE Module

Port	Priority Setting	Configuration Command ¹ and Resulting Operation with PDs connected to Ports C3 Through C24
C3 - C17	Critical	<p>In this example, the following CLI command sets ports C3-C17 to Critical:</p> <pre>ProCurve(config)# interface c3-c17 power-over-ethernet critical</pre> <p>The Critical priority class always receives power. If there is not enough power to provision PDs on all of the ports configured for this class, then no power goes to ports configured for High and Low priority. If there is enough power to provision PDs on only some of the critical-priority ports, then power is allocated to these ports in ascending order, beginning with the lowest-numbered port in the class, which, in this case, is port 3.</p>
C18 - C21	High	<p>In this example, the following CLI command sets ports C19-C22 to High:</p> <pre>ProCurve(config)# interface c19-c22 power-over-ethernet high</pre> <p>The High priority class receives power only if all PDs on ports with a Critical priority setting are receiving power. If there is not enough power to provision PDs on all ports with a high priority, then no power goes to ports with a low priority. If there is enough power to provision PDs on only some of the high-priority ports, then power is allocated to these ports in ascending order, beginning, in this example, with port 18, until all available power is in use.</p>
C22 - C24	Low	<p>In this example, the CLI command sets ports C23-C24 to Low²:</p> <pre>ProCurve(config)# interface c23-c24 power-over-ethernet low</pre> <p>This priority class receives power only if all PDs on ports with High and Critical priority settings are receiving power. If there is enough power to provision PDs on only some low-priority ports, then power is allocated to the ports in ascending order, beginning with the lowest-numbered port in the class (port 22, in this case), until all available power is in use.</p>
C1 - C2	- n/a -	<p>In this example, the CLI command disables PoE power on ports C1-C2:</p> <pre>ProCurve(config)# no interface c1-c2 power-over-ethernet</pre> <p>There is no priority setting for the ports in this example.</p>

¹ For a listing of PoE configuration commands, with descriptions, refer to “Configuring PoE Operation” on page 11-8.
² In the default PoE configuration, the ports are already set to the **low** priority. In this case, the command is not necessary.

PoE Priority With Two or More Modules

Ports across two or more modules can be assigned a class priority of either **Low** (the default), **High**, or **Critical**, for example, A5, B7, and C10 could all be assigned a priority class of **Critical**. When power is allocated to the ports on a priority basis, the **Critical** priority power requests are allocated to module A first, then Module B, C, and so on. Next, the **High** priority power requests are

allocated starting with module A, then B, C, and the remaining modules in order. Any remaining power is allocated in the same manner for the **Low** priority ports, beginning with module A though the remaining modules. If there is not enough PoE power for all the PDs connected to PoE modules in the switch, power is allocated according to priority class across modules. For example:

All ports on module C are prioritized as **Critical**.

```
ProCurve(config)# interface c1-c24 power-over-ethernet
                    critical
```

All ports on module A are prioritized as **Low**.

```
ProCurve(config)# interface a1-a24 power-over-ethernet
                    low
```

There are 48 PDs attached to all ports of modules A and C (24 ports each module).

There is only enough PoE power for 32 ports (8.5 watts x 32 ports = 273 watts).

The result is that all the **Critical** priority ports on module C would receive power, but only 8 ports on module A would receive power.

On module A, the port A1 has the highest priority of the ports in that module if all ports are in the same priority class, which is the case for this example. Since a minimum 17 + 5 watts of power is allocated per PoE module for PoE, port A1 will always receive PoE power. If another port on module A had a higher priority class than port A1, that port would be allocated the power before port A1.

For PoE+ modules there must be a minimum of 33 + 5 watts of power allocated per PoE+ module.

Controlling PoE Allocation

The default option for PoE allocation is **usage**, which is what a PD attached to the port is allocated. You can override this value by specifying the amount of power allocated to a port by using the **class** or **value** options.

Syntax: [no] int <port-list> poe-allocate-by [usage | class | value]

Allows you to manually allocate the amount of PoE power for a port by either its class or a defined value.

usage: *The automatic allocation by a PD*

class: *Uses the power ramp-up signature of the PD to identify which power class the device will be in. Classes and their ranges are shown in table 11-2.*

value: *A user-defined level of PoE power allocated for that port.*

Note

The allowable PD requirements are lower than those specified for PSEs to allow for power losses along the Cat-5 cable.

Table 11-2. Power Classes and Their Values

Power Class	Value
0	Depends on cable type and PoE architecture. Maximum power level output of 15.4 watts at the PSE. This is the default class; if there isn't enough information about the load for a specific classification, the PSE classifies the load as class 0 (zero).
1	Requires at least 4 watts at the PSE.
2	Requires at least 7 watts at the PSE.
3	15.4 watts
4	For PoE+ Maximum power level output of 30 watts at the PSE.

For example, to allocate by class for ports 6 - 8:

```
ProCurve(config)# int 6-8 PoE-allocate-by class
```

Manually Configuring PoE Power Levels

You can specify a power level (in watts) allocated for a port by using the **value** option. This is the maximum amount of power that will be delivered.

To configure a port by value, first set the PoE allocation by entering the **poe-allocate-by value** command:

```
ProCurve(config)# int A6 poe-allocate-by value
```

or in interface context:

```
ProCurve(eth-A6)# poe-allocate-by value
```

Then select a value:

```
ProCurve(config)# int A6 poe-value 15
```

or in interface context:

```
ProCurve(eth-A6)# poe-value 15
```

To view the settings, enter the **show power-over-ethernet** command:

```
ProCurve(config)# show power-over-ethernet A6

Status and Counters - Port Power Status for port A6

Power Enable      : Yes
Priority          : low
AllocateBy       : value
Detection Status : Delivering
LLDP Detect      : enabled
Configured Type  : 15 W
Value            : 15 W
Power Class      : 2
Over Current Cnt : 0
Power Denied Cnt : 0
MPS Absent Cnt  : 0
Short Cnt       : 0
Voltage         : 55.1 V
Current         : 154 mA
```

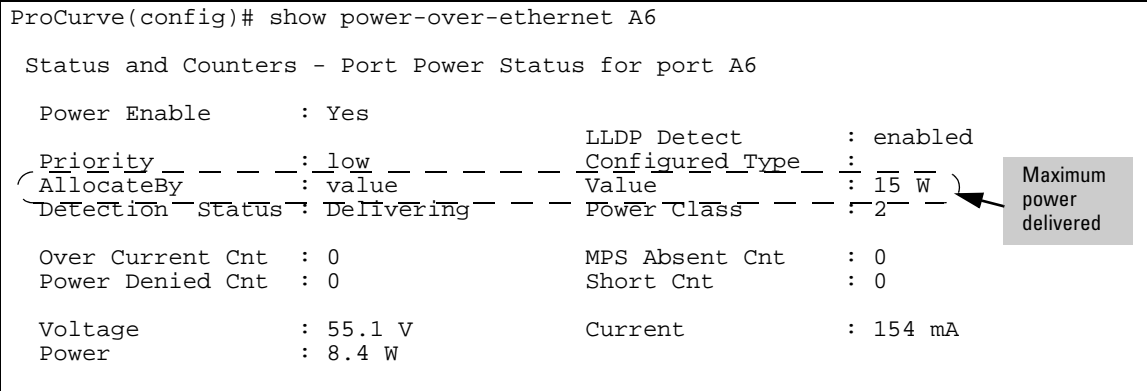

Figure 11-1. Example Displaying PoE Allocation by Value and the Maximum Power Delivered

If you set the PoE maximum value to less than the PD requires, a fault occurs.

```
ProCurve(config)# int A7 poe-value 4

ProCurve(config)# show power-over-ethernet A7

Status and Counters - Port Power Status for port A7

  Power Enable      : Yes
  Priority          : low
  AllocateBy _ _ _ : value _ _ _
  (Detection Status : fault _ _ _ )
  Over Current Cnt : 1
  Power Denied Cnt : 2
  Voltage          : 55.1 V
  Power           : 8.4 W

  LLDP Detect      : enabled
  Configured Type  :
  Value           : 4 W
  Power Class     : 2
  MPS Absent Cnt  : 0
  Short Cnt       : 0
  Current         : 154 mA
```

Figure 11-2. Example Showing PoE Power Value Set Too Low for the PD

Configuring PoE Redundancy (Chassis Switches Only)

When PoE redundancy is enabled, PoE redundancy occurs automatically. The switch keeps track of power use and won't supply PoE power to additional PoE devices trying to connect if that results in the switch not having enough power in reserve for redundancy if one of the power supplies should fail.

Syntax: [no] power-over-ethernet redundancy [n+1 | full]

Allows you to set the amount of power held in reserve for redundancy.

*The **no** option means that all available power can be allocated to PDs.*

Default: No PoE redundancy enforced.

n+1: *One of the power supplies is held in reserve for redundancy. If a single power supply fails, no powered devices are shut down. If power supplies with different ratings are used, the highest-rated power supply is held in reserve to ensure full redundancy.*

full: *Half of the available power supply is held in reserve for redundancy. If power supplies with different ratings are used, the highest-rated power supply is held in reserve to ensure full redundancy.*

See the *PoE Planning and Implementation Guide* for more information about PoE redundancy and power supplies, available on the ProCurve website at www.procurve.com

Changing the Threshold for Generating a Power Notice

You can configure one of the following thresholds:

- A global power threshold that applies to all modules on the switch. This setting acts as a trigger for sending a notice when the PoE power consumption on any PoE module installed in the switch crosses the configured global threshold level. (Crossing the threshold level in either direction—PoE power usage either increasing or decreasing—triggers the notice.) The default setting is 80%.
- A per-slot power threshold that applies to an individual PoE module installed in the designated slot. This setting acts as a trigger for sending a notice when the module in the specified slot exceeds or goes below a specific level of PoE power consumption.

Syntax: power-over-ethernet [slot < slot-id-range >] threshold < 1 - 99 >

This command specifies the PoE usage level (as a percentage of the PoE power available on a module) at which the switch generates a power usage notice. This notice appears as an SNMP trap and a corresponding Event Log message, and occurs when a PoE module's power consumption crosses the configured threshold value. That is, the switch generates a notice whenever the power consumption on a module either exceeds or drops below the specified percentage of the total PoE power available on the module.

This command configures the notification threshold for PoE power usage on either a global or per-module (slot) basis.

Without the [slot <slot-id-range>] option, the switch applies one power threshold setting on all PoE modules installed in the switch. For example, suppose slots A, B, and C each have a PoE module installed. In this case, executing the following command sets the global notification threshold to 70% of available PoE power.

```
ProCurve(config)# power-over-ethernet threshold  
70
```

With this setting, if module B is allocated 100 watts of PoE power and is using 68 watts, and then another PD is connected to the module in slot B that uses 8 watts, the 70% threshold of 70 watts is exceeded. The switch sends an SNMP trap and generates this Event Log message:

```
Slot B POE usage has exceeded threshold of 70%.
```

If the switch is configured for debug logging, it also sends the Event Log message to the configured debug destination(s).

On any PoE module, if an increasing PoE power load (1) exceeds the configured power threshold (which triggers the log message and SNMP trap), and then (2) later decreases and drops below the threshold again, the switch generates another SNMP trap, plus a message to the Event Log and any configured Debug destinations.

Syntax: power-over-ethernet [slot <slot-id-range>] threshold <1 - 99 >
(Continued)

To continue the preceding example, if the PoE power usage on the PoE module in slot B drops below 70%, another SNMP trap is generated and you will see this message in the Event Log:

Slot B POE usage is below threshold of 70%.

*For a message listing, refer to “” on page 11-28. (Default Global PoE Power Threshold: **80**). By using the [slot <slot-id-range>] option, you can specify different notification thresholds for different PoE modules installed in the switch. For example, you could set the power threshold for a PoE module in slot “A” to 75% and the threshold for the module in slot “B” to 68% by executing the following two commands:*

```
ProCurve(config)# power-over-ethernet slot a  
threshold 75
```

```
ProCurve(config)# power-over-ethernet slot b  
threshold 68
```

*Note that the last **threshold** command affecting a given slot supersedes the previous threshold command affecting the same slot. Thus, executing the following two commands in the order shown sets the threshold for the PoE module in slot “D” to 75%, but leaves the thresholds for any PoE modules in the other slots at 90%.*

```
ProCurve(config)# power-over-ethernet  
threshold 90
```

```
ProCurve(config)# power-over-ethernet slot d  
threshold 75
```

(If you reverse the order of the above two commands, all PoE modules in the switch will have a threshold of 90%.)

PoE/PoE+ Allocation Using LLDP Information

LLDP with PoE

When using PoE, enabling **poe-lldp-detect** allows automatic power configuration if the link partner supports PoE. When LLDP is enabled, the information about the power usage of the PD is available and the switch can then comply with or ignore this information. You can configure PoE on each port according to the PD (IP phone, wireless device, etc.) specified in the LLDP field. The default configuration is for PoE information to be ignored if detected through LLDP.

Note

Detecting PoE information via LLDP only affects power delivery; it does not affect normal Ethernet connectivity.

To enable or disable ports for allocating power using LLDP, use this command.

Syntax: `int <port-list> poe-lldp-detect [enabled | disabled]`

Enables or disables port(s) for allocating PoE power based on the link-partner's capabilities via LLDP.

Default: Disabled

For example, you can enter this command to enable LLDP detection:

```
ProCurve(config)# int A7 poe-lldp-detect enabled
```

or in interface context:

```
ProCurve(eth-A7)# poe-lldp-detect enabled
```

To enable PoE detection via LLDP TLV advertisement, use this command and insert the desired port or ports:

```
ProCurve(config)# lldp config <port-number>  
medTlvenable poe
```

Displaying the Switch's Global PoE Power Status

Syntax: show power-over-ethernet [brief | [ethernet] <port-list> | [slot <slot-id-range> | all]]

Displays the switch's global PoE power status, including:

- **Total Available Power:** Lists the maximum PoE wattage available to provision active PoE ports on the switch. This is the amount of usable power for PDs.
- **Total Failover Power:** Lists the amount of PoE power available in the event of a single power supply failure. This is the amount of power the switch can maintain without dropping any PDs.
- **Total Redundancy Power:** Indicates the amount of PoE power that is held in reserve for redundancy in case of a power supply failure.
- **Total Remaining Power:** The amount of PoE power still available.

brief: Displays PoE information for each port. See “Displaying PoE Status on All Ports” on page 11-21.

<port-list>: Displays PoE information for the ports in <port-list>. See “Displaying the PoE Status on Specific Ports” on page 11-23.

<slot-id-range>: Displays PoE information for the selected slots. (See figure 11-5). Enter the **all** option to display the PoE information for all slots.

For example, **show power-over-ethernet** displays data similar to that in figure 11-3.

Power Over Ethernet (PoE/PoE+) Operation
Displaying the Switch's Global PoE Power Status

```
ProCurve(config)# show power-over-ethernet

Status and Counters - System Power Status

Pre-standard Detect      : On
System Power Status     : No redundancy
PoE Power Status        : No redundancy

Chassis power-over-ethernet:

Total Available Power   : 600 W
Total Failover Power    : 300 W
Total Redundancy Power  : 0 W
Total used Power        : 9 W +/- 6W
Total Remaining Power   : 591 W

Internal Power
 1 300W/POE /Connected.
 2 300W/POE /Connected.
 3 Not Connected.
 4 Not Connected.

External Power
EPS1 /Not Connected.
EPS2 /Not Connected.
```

Figure 11-3. Example of show power-over-ethernet Command Output

Displaying PoE Status on All Ports

Syntax: show power-over-ethernet brief

Displays the following port power status:

- **PoE Port:** Lists all PoE-capable ports on the switch.
- **Power Enable:** Shows **Yes** for ports enabled to support PoE (the default) and **No** for ports on which PoE is disabled.
- **Power Priority:** Lists the power priority (**Low**, **High**, and **Critical**) configured on ports enabled for PoE. (For more on this topic, refer to the power command description under “Configuring PoE Operation” on page 11-8.)
- **Alloc by:** Displays how PoE is allocated (**usage, class, value**)
- **Alloc Power:** The maximum amount of PoE power allocated for that port (expressed in watts). Default: 17W for PoE; 33W for PoE+.
- **Actual Power:** The power actually being used on that port.
- **Configured Type:** If configured, shows the user-specified identifier for the port. If not configured, the field is empty.
- **Detection Status:**
 - **Searching:** The port is trying to detect a PD connection.
 - **Delivering:** The port is delivering power to a PD.
 - **Disabled:** On the indicated port, either PoE support is disabled or PoE power is enabled but the PoE module does not have enough power available to supply the port's power needs.
 - **Fault:** The switch detects a problem with the connected PD.
 - **Other Fault:** The switch has detected an internal fault that prevents it from supplying power on that port.
- **Power Class:** Shows the 802.3af power class of the PD detected on the indicated port. Classes include:

0: 0.44w to 12.95w can be drawn by the PD. Default class.	3: 6.49w to 12.95w
1: 0.44w to 3.84w	4: For PoE+; up to 25.5 watts can be drawn by the PD.
2: 3.84w to 6.49w	

Power Over Ethernet (PoE/PoE+) Operation

Displaying the Switch's Global PoE Power Status

For example, **show power-over-ethernet brief** displays this output:

```
ProCurve(config)# show power-over-ethernet brief

Status and Counters - Port Power Status

System Power Status      : No redundancy
PoE Power Status        : No redundancy

Available: 600 W  Used: 9 W  Remaining: 591 W

Module A Power
Available: 408 W  Used: 9 W  Remaining: 399 W

PoE Port | Power Enable | Power Priority | Alloc By | Alloc Power | Actual Power | Configured Type | Detection Status | Power Class
-----+-----+-----+-----+-----+-----+-----+-----+-----+-----
A1       | Yes          | low           | usage 17 W | 17 W         | 0.0 W        |                   | Searching        | 0
A2       | Yes          | low           | usage 17 W | 17 W         | 0.0 W        |                   | Searching        | 0
A3       | Yes          | low           | usage 17 W | 17 W         | 0.0 W        |                   | Searching        | 0
A4       | Yes          | low           | usage 17 W | 17 W         | 0.0 W        |                   | Searching        | 0
A5       | Yes          | low           | usage 17 W | 17 W         | 0.0 W        |                   | Searching        | 0
A6       | Yes          | low           | usage 17 W | 17 W         | 8.4 W        |                   | Delivering       | 2
A7       | Yes          | low           | usage 17 W | 17 W         | 0.0 W        |                   | Searching        | 0
A8       | Yes          | low           | usage 17 W | 17 W         | 0.0 W        |                   | Searching        | 0
A9       | Yes          | low           | usage 17 W | 17 W         | 0.0 W        |                   | Searching        | 0
```

Figure 11-4. Example of show power-over-ethernet brief Command Output

You can also show the PoE information by slot:

```
ProCurve(config)# show power-over-ethernet slot A

Status and Counters - System Power Status for slot A

Maximum Power      : 408 W          Operational Status : On
Power In Use       : 9 W +/- 6 W    Usage Threshold (%) : 80
```

Figure 11-5. Showing the PoE Information by Slot

Displaying the PoE Status on Specific Ports

Syntax: show power-over-ethernet <port-list >

Displays the following PoE status and statistics (since the last reboot) for each port in <port-list >:

- **Power Enable:** Shows **Yes** for ports enabled to support PoE (the default) and **No** for ports on which PoE is disabled. Note that for ports on which power is disabled, this is the only field displayed by **show power-over-ethernet < port-list >**.
- **Priority:** Lists the power priority (**Low**, **High**, and **Critical**) configured on ports enabled for PoE. (For more on this topic, refer to the power command description under “Configuring PoE Operation” on page 11-8.)
- **Allocate by:** How PoE is allocated (**usage**, **class**, **value**)
- **Detection Status:**
 - **Searching:** The port is available to support a PD.
 - **Delivering:** The port is delivering power to a PD.
 - **Disabled:** PoE power is enabled on the port but the PoE module does not have enough power available to supply the port's power needs.
 - **Fault:** The switch detects a problem with the connected PD.
 - **Other Fault:** The switch has detected an internal fault that prevents it from supplying power on that port.
- **Over Current Cnt:** Shows the number of times a connected PD has attempted to draw more than 15.4 watts for PoE or 24.5 watts for PoE+. Each occurrence generates an Event Log message.
- **Power Denied Cnt:** Shows the number of times PDs requesting power on the port have been denied due to insufficient power available. Each occurrence generates an Event Log message.
- **Voltage:** The total voltage, in Volts, being delivered to PDs.
- **Power:** The total power, in Watts, being delivered to PDs.
- **LLDP Detect:** Port is enabled or disabled for allocating PoE power based on the link-partner's capabilities via LLDP
- **Configured Type:** If configured, shows the user-specified identifier for the port. If not configured, the field is empty.
- **Value:** The maximum amount of PoE power allocated for that port (expressed in watts). Default: 17W for PoE; 33W for PoE+

Power Over Ethernet (PoE/PoE+) Operation

Displaying the Switch's Global PoE Power Status

- **Power Class:** Shows the power class of the PD detected on the indicated port. Classes include:

0: 0.44w to 12.95w **2:** 3.84w to 6.49w **4:** For PoE+; up to 25.5 watts can be drawn by the PD
1: 0.44w to 3.84w **3:** 6.49w to 12.95w

- **MPS Absent Cnt:** This value shows the number of times a detected PD has no longer requested power from the port. Each occurrence generates an Event Log message. ("MPS" refers to the "Maintenance Power Signature." Refer to "PoE Terminology" on page 11-3.)
- **Short Cnt:** Shows the number of times the switch provided insufficient current to a connected PD.
- **Current:** The total current, in mA, being delivered to PDs.

For example, if you wanted to view the PoE status of ports A6 and A7, you would use **show power-over-ethernet A6-A7** to display the data:

```
ProCurve(config)# show power-over-ethernet A6-A7

Status and Counters - Port Power Status for port A6

Power Enable      : Yes
Priority          : low
AllocateBy       : value
Detection Status : Delivering
LLDP Detect      : enabled
Configured Type  :
Value           : 17 W
Power Class      : 2

Over Current Cnt : 0
Power Denied Cnt : 0
MPS Absent Cnt  : 0
Short Cnt       : 0

Voltage          : 55.1 V
Power           : 8.4 W
Current          : 154 mA

Status and Counters - Port Power Status for port A7

Power Enable      : yes
Priority          : low
AllocateBy       : value
Detection Status : Searching
LLDP Detect      : disabled
Configured Type  :
Value           : 17 W
Power Class      : 0

Over Current Cnt : 0
Power Denied Cnt : 0
MPS Absent Cnt  : 0
Short Cnt       : 0

Voltage          : 0 V
Power           : 0 W
Current          : 0 mA
```

Figure 11-6. Example of Show Power-Over-Ethernet < port-list > Output

Planning and Implementing a PoE Configuration

This section provides an overview of some considerations for planning a PoE application. For additional information on this topic, refer to the *HP ProCurve PoE Planning and Implementation Guide* which is available on the ProCurve Networking web site at www.procurve.com. Select **Support**, and then click on **Manuals**.

Some of the elements you may want to consider for a PoE installation include:

- Port assignments to VLANs
- Use of security features
- Power requirements

This section can help you to plan your PoE installation. If you use multiple VLANs in your network, or if you have concerns about network security, you should read the first two topics. If your PoE installation comes close to (or is likely to exceed) the system's ability to supply power to all devices that may request it, then you should also read the third topic. (If it is unlikely that your installation will even approach a full utilization of the PoE power available, then you may find it unnecessary to spend much time on calculating PoE power scenarios.)

Power Requirements

In order to get the best PoE performance, you should provide enough PoE power to exceed the maximum amount of power that is needed by all the PDs that are being used.

By connecting an external power supply you can optionally provision more PoE wattage per port and or supply the switch with redundant 12V power to operate should an internal power supply fail.

By installing a second power supply in the 5406zl/8206zl or a third power supply in a 5412zl/8212zl chassis, depending on how many PoE ports are being supplied with power, the switch can have redundant power if one power supply fails. A Power Supply Shelf (external power supply) can also be connected to the 5400zl/8200zl switches to provide extra or redundant PoE power.

For example, if the 5406zl has two 24-port PoE modules (J8702A) installed, and all ports are using 15.4 watts, then the total wattage used is 739.2 watts (48 x 15.4). To supply the necessary PoE wattage a J8713A power supply is installed in one of the power supply slots.

To gain redundant power, a second J8713A must be installed in the second power supply slot. If the first power supply fails, then the second power supply can supply all necessary power.

See the *HP ProCurve PoE Planning and Implementation Guide* for detailed information about the PoE/PoE+ power requirements for your switch.

Assigning PoE Ports to VLANs

If your network includes VLANs, you may want to assign various PoE-configured ports to specific VLANs. For example, if you are using PoE telephones in your network, you may want to assign ports used for telephone access to a VLAN reserved for telephone traffic.

Applying Security Features to PoE Configurations

You can utilize security features built into the switch to control device or user access to the network through PoE ports in the same way as non-PoE ports.

- **MAC Address Security:** Using Port Security, you can configure each switch port with a unique list of MAC addresses for devices that are authorized to access the network through that port. For more information, refer to the chapter titled “Configuring and Monitoring Port Security” in the *Access Security Guide* for your switch.

Assigning Priority Policies to PoE Traffic

You can use the configurable QoS (Quality of Service) features in the switch to create prioritization policies for traffic moving through PoE ports. Table 11-3 lists the available classifiers and their order of precedence.

Table 11-3. Classifiers for Prioritizing Outbound Packets

Priority	QoS Classifier
1	UDP/TCP Application Type (port)
2	Device Priority (destination or source IP address)
3	IP Type of Service (ToS) field (IP packets only)
4	VLAN Priority
5	Incoming source-port on the switch
6	Incoming 802.1p priority (present in tagged VLAN environments)

For more on this topic, refer to the chapter titled “Quality of Service: Managing Bandwidth More Effectively” in the *Advanced Traffic Management Guide* for your switch.

PoE Event Log Messages

PoE operation generates these Event Log messages. You can also configure the switch to send these messages to a configured debug destination (terminal device or SyslogD server).

“Informational” PoE Event-Log Messages

Message	Meaning
I <MM/DD/YY> <HH:MM:SS> <chassis ports>	Message header, with severity, date, system time, and system module type (chassis or ports). For more information on Event Log operation, including severity indicators, refer to “Using the Event Log for Troubleshooting Switch Problems” on page C-27
Slot <slot-id> POE usage is below configured threshold of <1-99>%	Indicates that POE usage on the module in the indicated slot has decreased below the threshold specified by the last execution of the power threshold command affecting that module. This message occurs if, after the last reboot, the PoE demand on the module exceeded the power threshold and then later dropped below the threshold value.
port <port-id> applying power to PD	A PoE device is connected to the indicated port and receiving power.
port <port-id> PD detected	The switch has detected a PoE device connected to the indicated port.
Slot <slot-id> software update started on PoE controller <controller-id>	A module needs to have its PoE firmware updated and the software begins the update process. On ProCurve 8212zl switches the controller-id is always “1”
Slot <slot-id> software update completed on PoE controller <controller-id>	A module has its PoE firmware updated and the software has finished this process.

“Warning” PoE Event-Log Messages

Message	Meaning
W <MM/DD/YY> <HH:MM:SS> chassis	Message header, with severity, date, system time, and system module type. For more information on Event Log operation, including severity indicators, refer to “Using the Event Log for Troubleshooting Switch Problems” on page C-27”.
Slot <slot-id> POE usage has exceeded threshold of <1-99>%	Indicates that POE usage in the indicated slot has exceeded the configured threshold for the module, as specified by the last execution of the power threshold or power slot < slot-id > threshold command. (Note that the switch also generates an SNMP trap for this event.)
Port <port-id>PD Denied power due to insufficient power allocation.	There is insufficient power available to power the PD on the indicated port and the port does not have sufficient PoE priority to take power from another active PoE port.
Port <port-id> PD Invalid Signature indication	The switch has detected a non-802.3af-compliant or non-802.3at-compliant device on the indicated port. This message appears for all non-802.3af devices connected to the port, such as other switches, PC-NICs, etc.
Port <port-id> PD MPS Absent indication	The switch no longer detects a device on < port-id >. The device may have been disconnected, powered down, or stopped functioning.
Port <port-id>PD Other Fault indication	There is a problem with the PSE connected to the port.
Port <port-id>PD Over Current indication	The PD connected to < port-id > has requested more than 15.4 watts of power. This may indicate a short-circuit or other problem in the PD.
50v Power Supply is faulted. Failures:<num-failures>	Internal power supply has faulted.
50v Power Supply is OK. Failures: <num-failures>	Internal power supply is now OK.
FET bad on port <port-id>	External FET (Field Effect Transistor) on the port has gone bad and cannot deliver power.

Power Over Ethernet (PoE/PoE+) Operation
PoE Event Log Messages